

KEIR & ASSOCIATES

Consulting, Engineering & Project Management



CONSULTING ENGINEERING & PROJECT MANAGEMENT

ABOUT US

Keir & Associates (Pty) Ltd is a well established engineering consulting company which has been involved in serving local and international markets since 1989.

As a multi-disciplinary organisation, we take projects from initial pre-feasibility studies through to final implementation and commissioning. No project is too big or too small for our team of experienced engineers. Our designs assure efficient, cost effective engineered solutions.

For more than 30 years Keir & Associates (Pty) Ltd has been proud to provide a professional service, whilst partnering with our clients, to execute their specific project requirements. We can assist with engineering projects and design whether the scope is all-inclusive or it is limited to an aspect of the project.

Keir & Associates (Pty) Ltd is led by a team of young engineers who are guided by experienced specialists with engineering skills in:

- ✓ Mechanical
- ✓ Process
- ✓ Electrical and Automation
- ✓ Civil and Structural
- ✓ Draughting
- ✓ Quantity Surveying

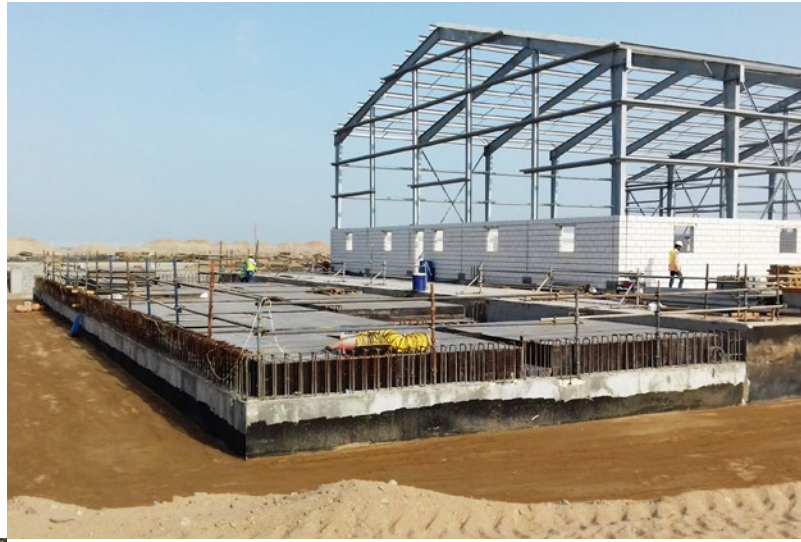

Your project can be augmented with project and construction managers to provide a fully comprehensive service. We operate in many different sectors, eg:

- ✓ Sugar
- ✓ Industrial
- ✓ Waste Water
- ✓ Energy
- ✓ Infrastructure Development

OUR FOCUS AREAS

- Civil, Structural, Mechanical, Electrical Design
- Process and Piping Design
- Pressure Vessel Design
- Packing Stations & Warehousing
- Materials Handling & Conveying Systems
- Dust Control

- Food Safety System Compliance
- Feasibility Studies
- Hazop Studies
- Factory Logistics
- Pressure Vessel Design and Certification



OUR SERVICES



PROJECT MANAGERS & CONSULTANTS

We provide a comprehensive Project Management service where cost is managed carefully, time effectively and technical excellence is ensured.



MATERIALS HANDLING & WAREHOUSING

We undertake materials handling design from bulk to despatch, including all packing, palletising and warehousing activities in-between.



ENGINEERING DESIGN SERVICES

We have a Design & Draughting facility fully reinforced with up-to-date knowledge of the latest design, service codes & standards used worldwide.



SUGAR PROCESSING, STORAGE & CONDITIONING

Keir & Associates is recognised worldwide as an authority on the storage and handling of sugar. We've designed & installed systems around the globe.

PROJECT MANAGEMENT

Keir & Associates (Pty) Ltd provides a comprehensive Project Management service for our clients where cost is managed carefully, time effectively and technical excellence is ensured. We partner with your Project Managers to provide a service which complements your needs to make your team more effective.

As Project Managers, Keir & Associates (Pty) Ltd realise the importance of having the right skills and knowledge within the team so that effective control, and audit, can be exercised over the Design Engineers and Contractors. Our professionals are well versed in a range of technologies so that we can deliver an effective service using sound project management principles. It is important for Keir & Associates (Pty) Ltd to successfully partner with our Clients so to establish the project structure best suited to their needs.

PROJECT MANAGEMENT SERVICES INCLUDE:

- ✓ Feasibility / Front End Studies
- ✓ Construction Management
- ✓ Technical Auditing
- ✓ Project Scheduling
- ✓ Contract Administration
- ✓ Risk Management
- ✓ Cost Control
- ✓ Commissioning and Handover
- ✓ Supervision & Audit of Design
- ✓ Procurement – Contract Strategies and Administration
- ✓ Quality Management



NEW BOILER & T.A. SET

Project Outline

Installation of Carbon Burnout Boiler

Location

Mauritius

Scope

Project and Construction Management



ESWATINI SUGAR ASSOCIATION

Project Outline

Construction of 25,000 ton Conditioning Silo

Location

Eswatini

Scope

Project Management, Technical Audit & Design



PORT SIDE SUGAR REFINERY

Project Outline

750 000 ton / year sugar refinery

Location

Lagos, Nigeria

Scope

Technical Audit, Cost Control & Design



SAUDI BIO-ACIDS COMPANY

Project Outline

60 TPH Citric Acid Plant

Location

Saudi Arabia

Scope

Engineering, Procurement & Construction Management



OMNICANE

Project Outline

New Sugar Conditioning Silos & Bulk Storage

Location

Mauritius

Scope

Engineering, Procurement & Construction Management

MATERIALS HANDLING & WAREHOUSING

Keir & Associates (Pty) Ltd undertake materials handling design from bulk to despatch, which includes all packing, palletising and warehousing activities.

Materials handling design initially focuses on conceptual layouts. Client specific, we are able to take a project further as we have the capability to provide a complete engineering solution.

DESIGN & RECONFIGURATION

- ✓ All Systems to Bulk Material in Factories and Silos
- ✓ Packing Stations for a Variety of Pack Sizes
- ✓ Automated Palletising Systems
- ✓ Sorting, Picking and Indexing
- ✓ Warehouse & Warehousing Systems
- ✓ Truck Loading Stations
- ✓ Drum Filling System
- ✓ Civil, Structural & Electrical Works
- ✓ Unit Handling System
- ✓ Food Safety System Compliance



UBOMBO WAREHOUSE

Project Outline

20 000 ton bagged sugar storage, warehouse & bagging plant

Location

Eswatini

Scope

Engineering, Procurement & Construction Management



SIMUNYE WAREHOUSE

Project Outline

80 000 ton bagged sugar storage, warehouse & bagging plant

Location

Eswatini

Scope

Engineering, Procurement & Construction Management



UBOMBO WAREHOUSE EXTENSION

Project Outline

20 000 ton bagged sugar storage, warehouse & bagging plant

Location

Eswatini

Scope

Engineering, Procurement & Construction Management

ENGINEERING SERVICES

Keir & Associates (Pty) Ltd offer comprehensive design and engineering solutions to our clients.

We have a Design & Draughting facility fully reinforced with up-to-date knowledge of the latest design service codes and standards used worldwide. A combination of the latest designing software and a dedicated group of highly motivated professionals enables us to provide across-the-board design and engineering services.

Engineering services could range from geotechnical evaluations to unique process design and optimisation.

CIVIL ENGINEERING
DESIGN

MECHANICAL
ENGINEERING DESIGN

PROCESS
ENGINEERING

ELECTRICAL &
INSTRUMENTATION

These services encompass all fields of engineering. Keir & Associates (Pty) Ltd will go a step further to offer a personal, yet interactive experience allowing the client any combination of these services.

Whatever the client's requirements, the emphasis remains on maintaining technical excellence and applying fit-for-purpose technological solutions.

CIVIL ENGINEERING DESIGN

- ✓ Earthworks
- ✓ Industrial Buildings
- ✓ Precast Elements
- ✓ Concrete Repairs
- ✓ Specialist Designs
- ✓ Reservoirs
- ✓ Bridges
- ✓ Lifting Beams
- ✓ Supports
- ✓ Repairs
- ✓ Building Information Modelling
- ✓ Code Compliance Assessments (All Building Codes)
- ✓ Modelling and Detailing of Structures
- ✓ Quantity Surveying Services



MECHANICAL ENGINEERING DESIGN

- ✓ Storage Tanks, Pressure Vessel's, Heat Exchangers, Silo's
- ✓ Power, Low & High Pressure Piping Corridor Piping
- ✓ Pressure Piping & Fittings,
- ✓ Ducting & Fume Stack Systems
- ✓ Gas Transmission Lines
- ✓ Agitators & Mixers
- ✓ Finite Element Analysis
- ✓ Failure Analysis
- ✓ CAESAR II – Flexibility Analysis
- ✓ Code Certification
- ✓ Code Inspections
- ✓ Fuel Tank Farms
- ✓ Dust Extraction System Design
- ✓ 3D Modelling of Plant Systems



STRUCTURAL STEEL DETAIL & MODELLING



PIPE & TANK DETAILING & MODELLING

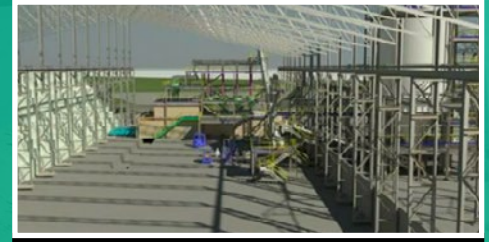

PLANT & EQUIPMENT LAYOUT & MODELLING

PROCESS ENGINEERING

- ✓ 3D Modelling
- ✓ Plant Design
- ✓ Hazop and Food Safety System Compliance (FSSC)
- ✓ Process Flowsheets, Conceptual Layout and P&I Diagrams

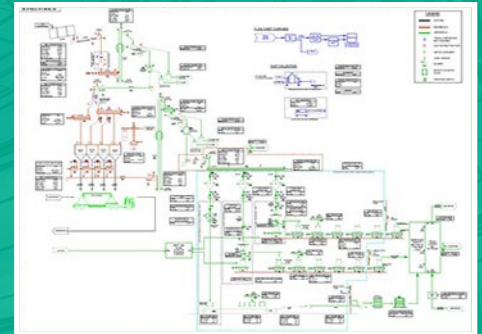
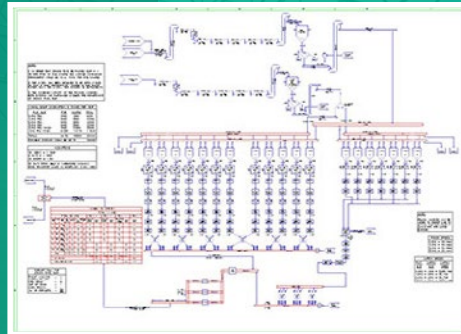
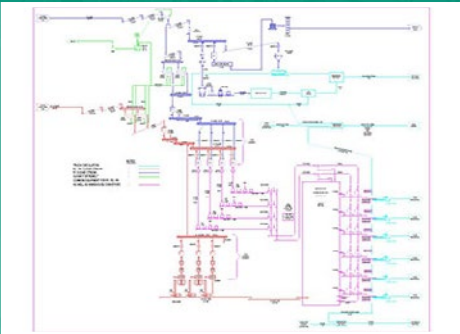

ELECTRICAL & INSTRUMENTATION

- ✓ Motor Control Centres
- ✓ Electrical Reticulation & Specifications
- ✓ FDS (Functional Design Specifications)
- ✓ PLC Cabinets
- ✓ Instrument Selection



SUGAR PROCESSING, STORAGE & CONDITIONING

Keir & Associates (Pty) Ltd is recognised worldwide as an authority on the storage and handling of sugar. We have designed and installed systems which involve:

- Ship to shore including bulk storage up to 80 000 tons
- VHP sugar handling from centrifugals to packing station and loading docks
- Refined sugar handling from centrifugals to packing station and loading docks
- Refined sugar conditioning and handling around the conditioning silo



Materials Handling
(all forms of conveying)



Sugar Conditioning



Sugar Refining



Dust Control



Sugar Storage
and Packing



Food Safety System
Compliance



Hazop Studies

Keir & Associates (Pty) Ltd has been active in these markets since 1996 and continue to provide cutting edge technology to Clients around the world in:

- ✓ Conveying Systems
- ✓ Bulk Stores
- ✓ Conditioning
- ✓ Packing Stations
- ✓ Dust Control
- ✓ Bagged Warehousing
- ✓ Cleaning and Screening
- ✓ Castor Manufacture
- ✓ Soft Brown Manufacture
- ✓ Icing Manufacture
- ✓ Cube Manufacture
- ✓ Clean Room Environments
- ✓ Specialised Sugar Equipment



BULK SUGAR STORES

Keir & Associates (Pty) Ltd have designed and built bulk sugar stores ranging from 25 – 80 thousand tons.

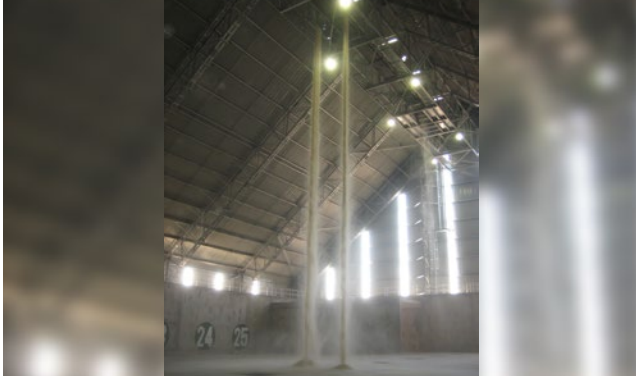

PORT SIDE BULK SUGAR STORE

Project Outline

Bulk Sugar Store 50 000 ton

Location

Mozambique

Scope

Engineering, Procurement and Construction Management



BACK END REFINERY BULK SUGAR STORE

Project Outline

Bulk Sugar Store 60 000 ton

Location

Mauritius

Scope

Design, Engineering and Audit



BACK END REFINERY BULK SUGAR STORE

Project Outline

Bulk Sugar Store 55 000 ton

Location

Mauritius

Scope

Design, Engineering and Audit



PORT SIDE BULK SUGAR STORE

Project Outline

Bulk Sugar Store 50 000 ton

Location

Mauritius

Scope

Engineering, Procurement & Construction Management



PORT SIDE BULK STORE

Project Outline

Bulk Sugar Store 80 000 ton – Design

Location

Nigeria

Scope

Design, Engineering and Audit

SUGAR CONDITIONING

The silo is designed to suit the market it serves. The systems we have designed accommodate the requirements for packing conditioned sugar into a range of packaging from small retail bags up to large bulk packing in 25 Ton bulk bags.

Keir & Associates (Pty) Ltd have designed and built numerous sugar conditioning silos since 1990.



CONDITIONING SILO – BACK END REFINERY

Project Outline

1800 ton Conditioning Silo

Location

Mauritius

Scope

Engineering, Procurement & Construction Management



CONDITIONING SILO – BACK END REFINERY

Project Outline

1800 ton Conditioning Silo

Location

Mauritius

Scope

Design, Engineering and Audit



CONDITIONING SILO – BACK END REFINERY

Project Outline

25 000 ton Conditioning Silo

Location

Eswatini

Scope

Design and Technical Audit



CONDITIONING SILO – BACK END REFINERY

Project Outline

2 400 ton Conditioning Silo

Location

Mauritius

Scope

Engineering, Procurement & Construction Management

PACKING STATIONS

Keir & Associates (Pty) Ltd specialise in design and installation of sugar packing stations. In the last 30 years, we have been involved with the building or the modification of over 30 packing stations. The stations sizes have ranged from 12 to 250 TPH.

The type of sugar packed has included Coarse, Broken Cone, Refined, VHP, Raw and Soft Brown.

Pack sizes have ranged from 900g to 25 ton containers.

Where necessary we have worked with our Clients to ensure they comply with the HACCP and FSSC 22 000 food safety requirements.



SAVOLA PACKING PLANT

Project Outline

Sugar & Broken Cone Packing Plant in retail packs

Location

Iran

Scope

Engineering, Procurement & Construction Management



BOOKER TATE / SAVOLA – RETAIL PACKING PLANT

Project Outline

272 000 ton per year Packing Plant for a range of retail packs

Location

Saudi Arabia

Scope

Engineering, Design and Technical Audit



BULK SUGAR BAGGING PLANT

Project Outline

Bagging of VHP Sugar in 50 kg and 1 ton bags
Palletising, unit handling and storage

Location

Eswatini

Scope

Engineering, Procurement and Construction Management



UNIT HANDLING

Project Outline

Conveying and handling of retail rice packs

Location

South Africa

Scope

Engineering, Design and Technical Audit



AUTO PALLETISING

Project Outline

Auto palletising of rice packs

Location

South Africa

Scope

Restoration of auto palletising system
Engineering and Procurement



UNIT HANDLING

Project Outline

Baling, cartoning and unit handling of multiple stock units to palletising points

Location

Saudi Arabia

Scope

Engineering, Procurement and Technical Audit



CONTACT US



+27 31 764 4300
+27 31 764 4301



dave@keirprojects.com
vinay@keirprojects.com

OPERATING HOURS



MONDAY – FRIDAY 08.00 – 16.00

WHERE TO FIND US



23 Old Main Road, Gillitts
KwaZulu-Natal, South Africa
PO Box 660, Hillcrest 3650

